

- D** **Ergänzung zur Anleitung für Montage und Betrieb**
Garagenschwinger (Vorschlag für bauseitige Verbretterung senkrecht oder Fischgrät)
- GB** **Supplementary information for 'Fitting and operating instructions'**
Up-and-over garage door (Proposal for vertical or chevron infill on site)
- F** **Complément aux instructions de montage et d'utilisation**
Porte de garage basculante (Proposition pour remplissage bois vertical ou à chevrons par l'utilisateur)
- NL** **Bijlage aan de montage- en bedieningshandleiding**
Kanteldeur voor garages (Voorstel voor houtvulling, verticaal of in visgraatmotief)
- E** **Ampliación de instrucciones para el montaje y funcionamiento**
Puerta de garaje basculante (Sugerencia para forrar en obra, vertical o espiga)
- I** **Aggiunta alle istruzioni per il montaggio e l'uso**
Porta basculante per garage (Suggerimento per un riempimento in legno verticale o a spina di pesce, a cura del cliente)
- P** **Complemento das instruções para montagem e uso**
Portão de garagem basculante (Proposta para revestimento com madeira vertical ou em espinha de peixe na construção)
- PL** **Uzupełnienie instrukcji montażu i eksploatacji**
Uchylna brama garażowa (Propozycja indywidualnego wypełnienia deskami pionowymi lub w jodełkę)
- H** **Kiegészítés a szerelési és üzemeltetési útmutatóhoz**
Billeń garażkapu (Javaslat a házilagós burkolásra, függőleges és halszálka mintázat esetén)
- CZ** **Doplňek k návodu k montáži a obsluze**
Výklopná garážová vrata (Návrh na obložení sestavené na místě montáže ze svislých prvků nebo z prvků sestavených do vzoru rybi kosti)
- RUS** **Дополнение к руководству по монтажу и эксплуатации**
Среднеподвесные гаражные ворота (Предложение по обивке планками на месте монтажа, по вертикали или методом "рыбная чешуя")
- SLO** **Dodatek k Navodilu za vgradnjo in vzdrževanje**
Garažna dvizna vrata (Predlog za naccin polaganja desk-navpično ali po črtastem vzorcu)
- N** **Supplering av veiledning for montering og bruk**
Vippeporter for garasjer (Forslag til paneling - stående- eller fiskeben - på monteringsstedet)
- S** **Tillägg till instruktionerna för montage och handhavande**
Vippport (Förslag för egen brædfodring lodræt eller fiskbensmønstrad)
- FIN** **Lisäys asennus- ja käyttöohjeeseen**
Autotallin kippiovi (Ehdotus rakennuspaikalla tehtävään pystysuoraan tai kalanruodon malliseen laudoitukseen)
- DK** **Tillæg til vejledning for montering og bruk**
Garagevippeport (Forslag for egn montering af brædder lodret eller fiskebensmønster)
- SK** **Doplnenie k návodu na montáž a údržbu**
Výklopná garážová brána (návrh na výplň doskami zo strany stavebníka zvisle alebo na rybinu)
- TR** **Montaj ve İşletim Kılavuzu'na Ek Bilgi**
Yekpare garaj kapısı (isteğe bağlı olarak lamellerin dikey veya balk sırtı şeklinde yerleştirilmesi ile kapı kanadının kaplanması için öneri)
- LT** **Montavimo ir eksploatacijos instrukcijos papildymas**
Plokštuminiai garažo vartai (pasiūlymas vertikaliems arba eglute išdėstytais grioveliais)
- EST** **Paigaldus- ja kasutusjuhendi täiendus**
Garažikäänduks (kohapeal paigaldatava vertikaalse või kalasabamustrilise laudisvoodri paigalduse soovitus)
- LV** **Montāžas un ekspluatācijas instrukcijas papildinājums**
Garāžas paceļamie vārti (klienta veikta apdare, vertikāla vai skujiņā)
- HR** **Dopuna uputi za montažu i pogon**
Garažna krilno podizna vrata (prijedlog za oblaganje drvom s vanjske strane, okomito ili nakošeno)
- SCG** **Dopuna uputstvu za montažu i pogon**
Krilno podizna garažna vrata (predlog za oblaganje drvenim profilima tokom ugradnje vrata, i to vertikalno ili riblja kost)
- GR** **Συμπλήρωμα στις οδηγίες συναρμολόγησης και χειρισμού**
Μονοκόμματη γκαραζόπορτα (Πρόταση για την τοποθέτηση δοκών κάβεται ή σε διάταξη "ψαροκόκκαλου")
- RO** **Completare la instrucțiunile de montaj și funcționare**
Ușă de garaj basculantă (proponere pentru placarea individuală cu scânduri din lemn în formă verticală sau sub formă de solzi de pește)
- BG** **Допълнение към упътване за монтаж и пускане в експлоатация**
Гаражна врата тип летящо крило (вариант за индивидуално оформление във вертикално изпълнение или рибена кост)

DEUTSCH

Wichtige Hinweise:

- Beachten Sie die Hinweise der Anleitung für Montage und Betrieb!
- Torblatt ohne Füllung gegen Aufspringen sichern!
- Max. zulässige Torblattgewichte siehe Anleitung für Montage und Betrieb!

Der Profil-Halbzyylinder ist für eine Füllungs-
dicke von max. 19 mm geeignet (Füllung im
Rahmen). Bei höherer Füllung anderen Profil-
Halbzyylinder anfordern (Mehrpreis).

Urheberrechtlich geschützt.
Nachdruck, auch auszugsweise,
nur mit unserer Genehmigung.
Änderungen vorbehalten.

ENGLISH

Important:

- Respect the 'Fitting and operating instructions'!
- Secure open-for-infill door leaf against unintended opening!
- For max. infill weights see 'Fitting and operating instructions'!

The profile half cylinder is suitable for infills
max. 19 mm thick (infill in frame).

Should the infill be thicker please ask for a
different type of profile half cylinder
(surcharge).

Copyright.

No reproduction even in part is allowed
without our permission.

All details subject to change.

FRANÇAIS

Instructions importantes:

- Observer les instructions de montage et d'utilisation!
- Protéger le tablier sans remplissage contre l'ouverture brusque!
- Poids maximum autorisé du tablier voir instructions de montage et d'utilisation!

Le cylindre profilé convient pour un
remplissage de max. 19 mm d'épaisseur
(remplissage dans le cadre). En cas d'un
poids de remplissage plus important un
autre cylindre profilé doit être utilisé
(supplément).

Droits d'auteur réservés.

Reproduction même partielle uniquement avec
notre autorisation. Changements réservés.

NEDERLANDS

Belangrijke richtlijnen:

- Let op de richtlijnen van de montage- en bedieningshandleiding!
- Deurblad zonder vulling tegen het opspringen beveiligen!
- Maximum toelaatbaar deurbladgewicht zie montage- en bedieningshandleiding!

De profielcilinder is geschikt voor een
vullingsdikte van max. 19 mm (inliggende
vulling). Bij een hoger vullingsgewicht moet
een andere profielcilinder gebruikt worden
(meerprijs).

Door de auteurswet beschermd.
Gehele of gedeeltelijke nadruk alleen
toegelaten mits onze toestemming.
Wijzigingen voorbehouden.

ESPAÑOL

Notas importantes:

- Observe las instrucciones de montaje y funcionamiento!
- Asegurar la hoja sin forro contra la apertura accidental!
- Peso máx. permitido de la hoja, ver instrucciones de montaje y funcionamiento!

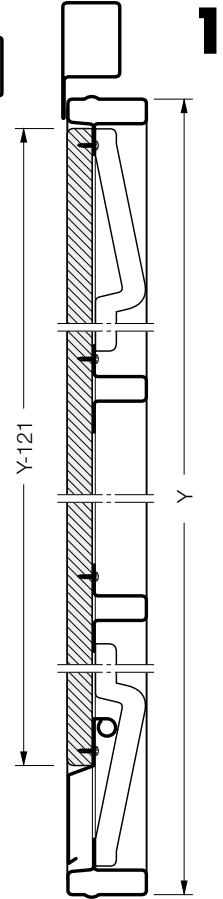
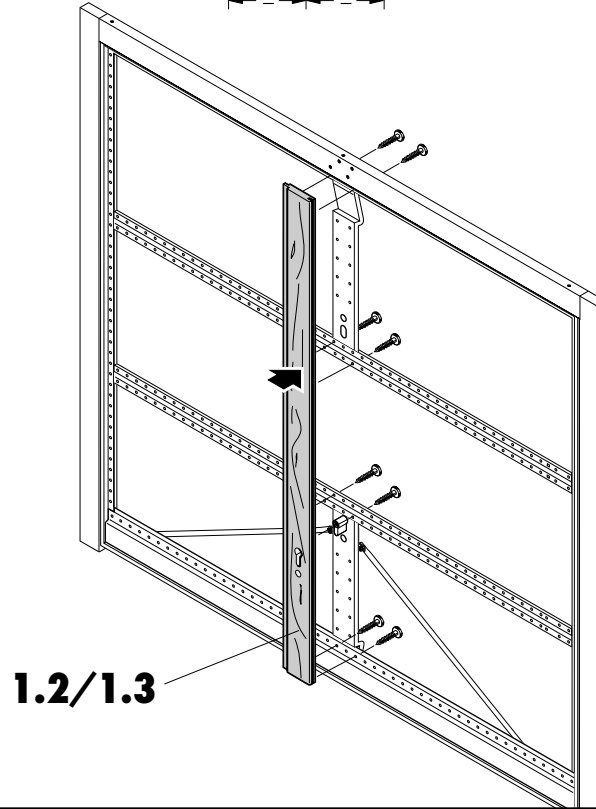
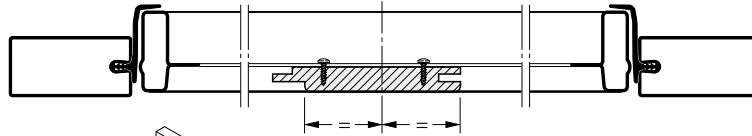
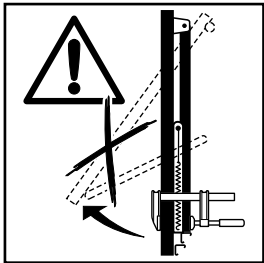
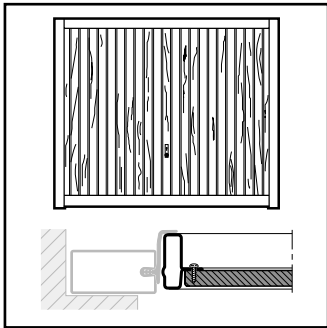

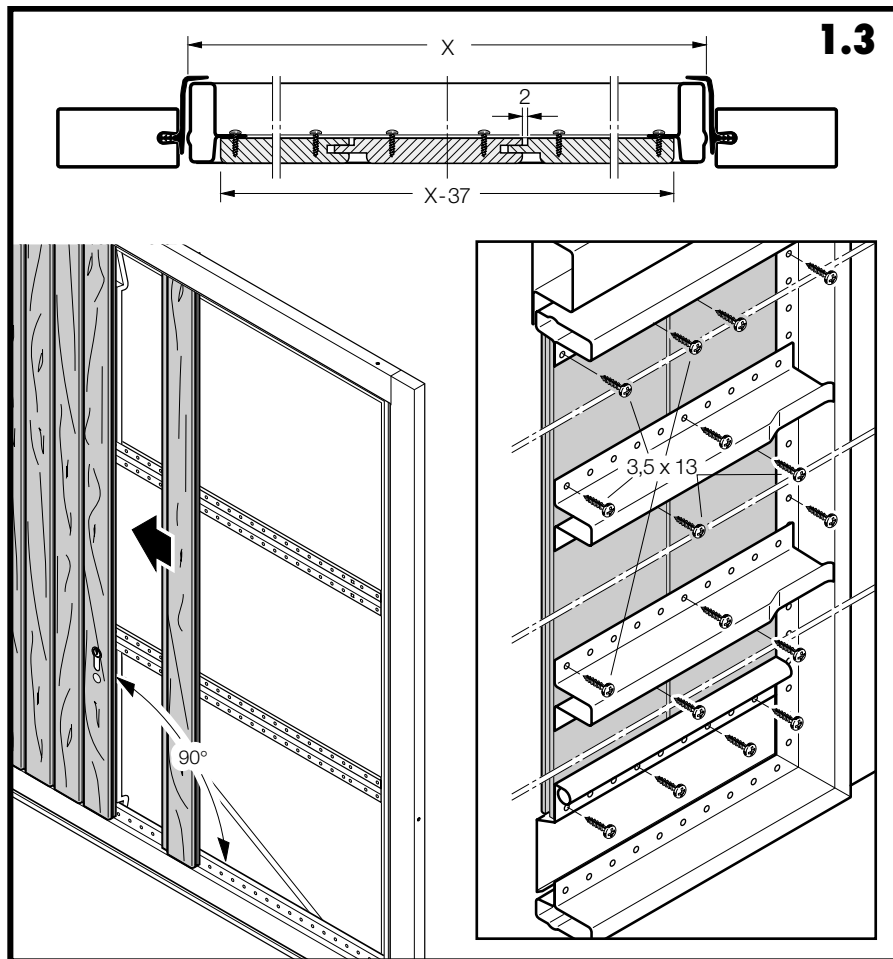
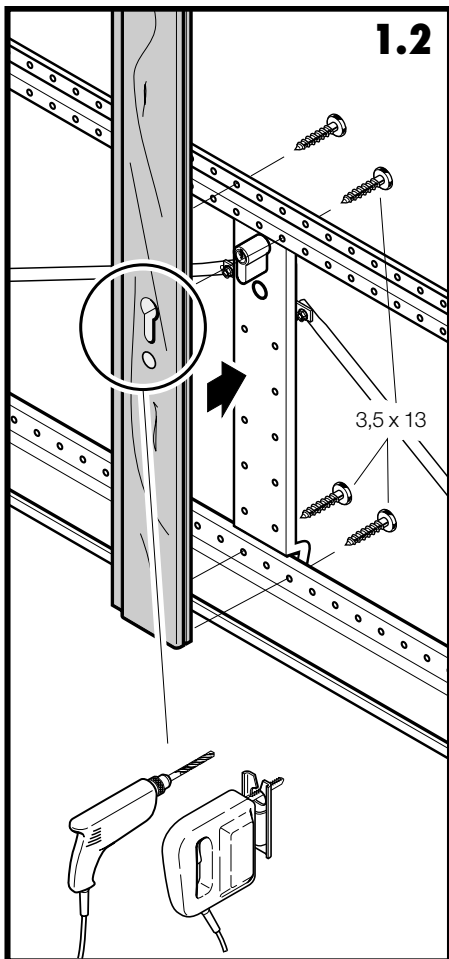

2

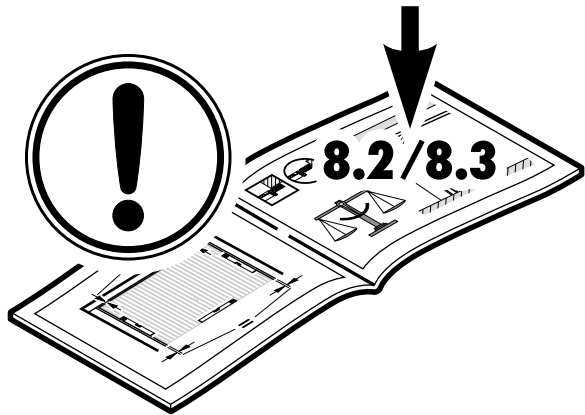
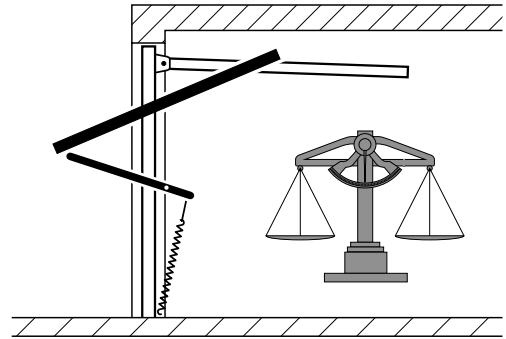
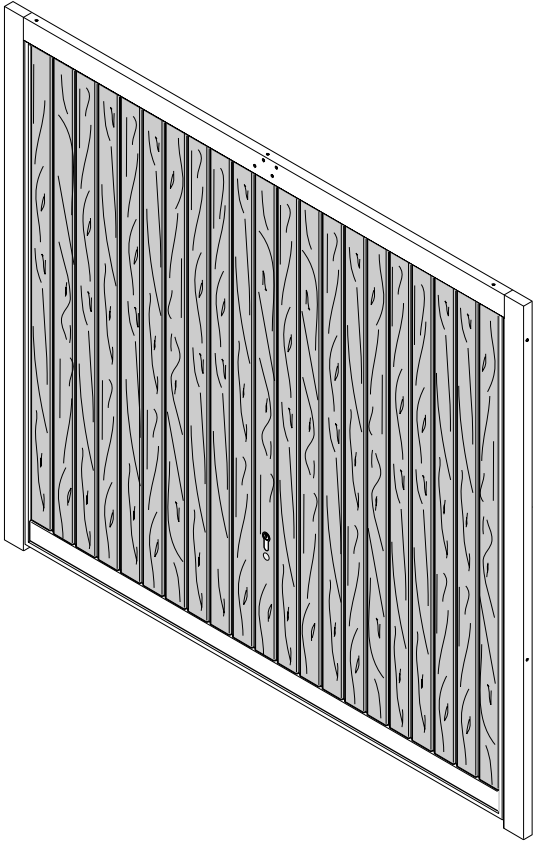

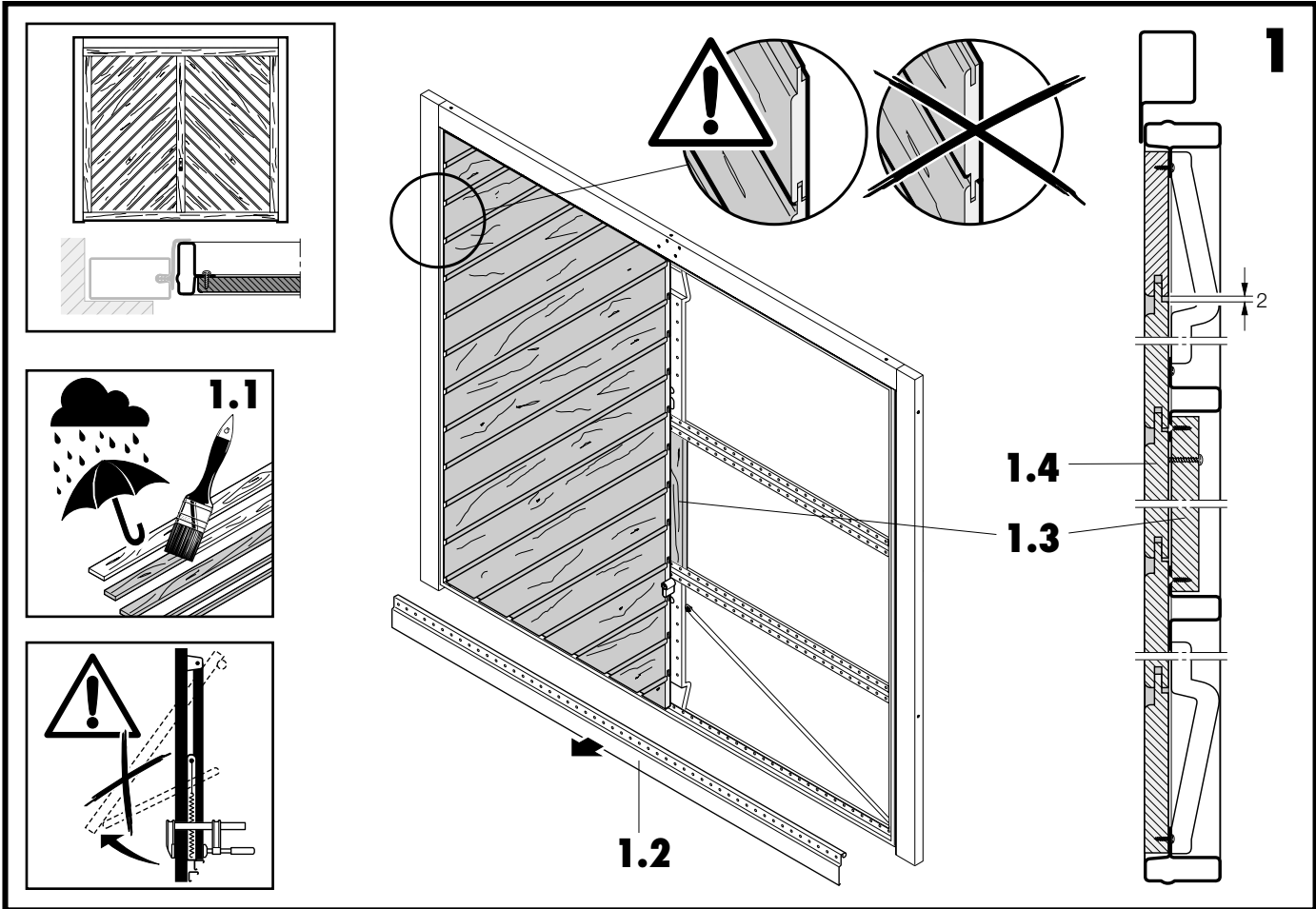

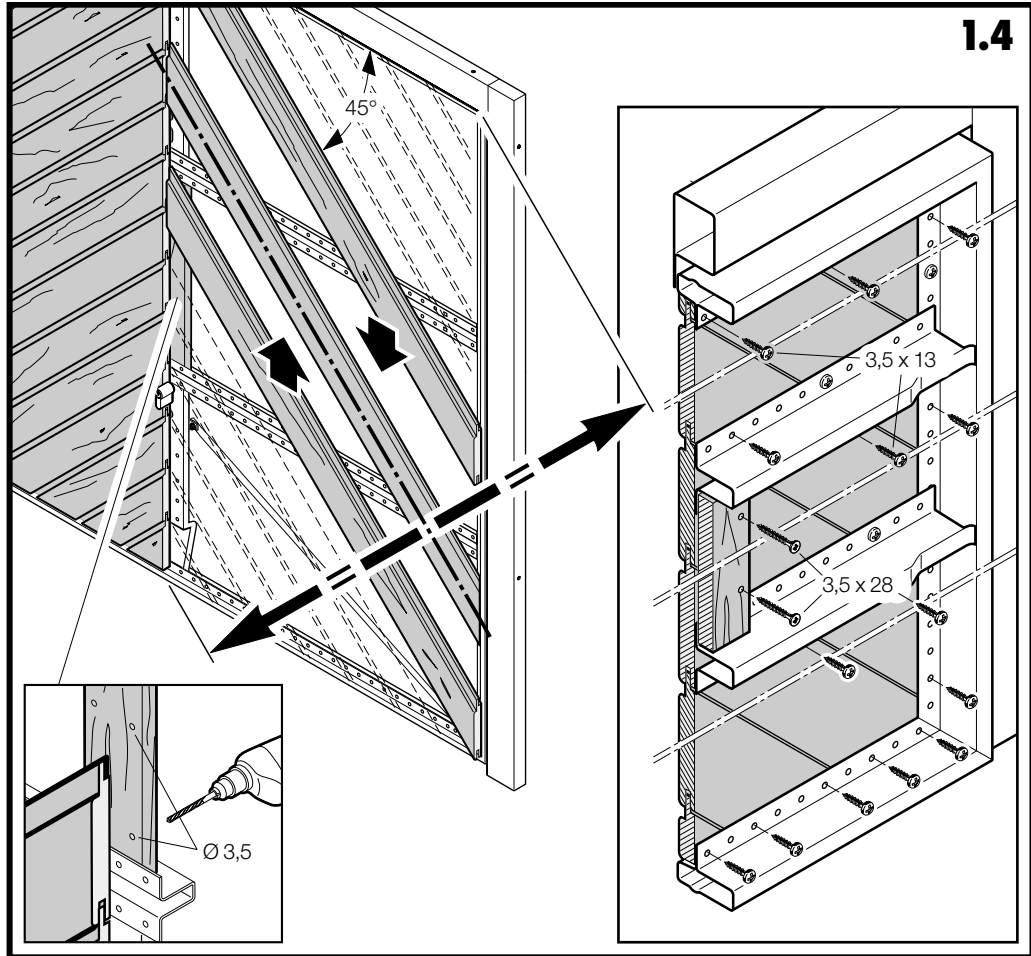
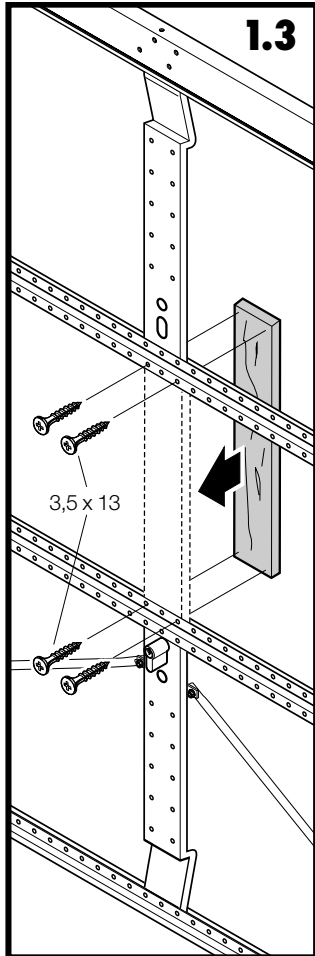

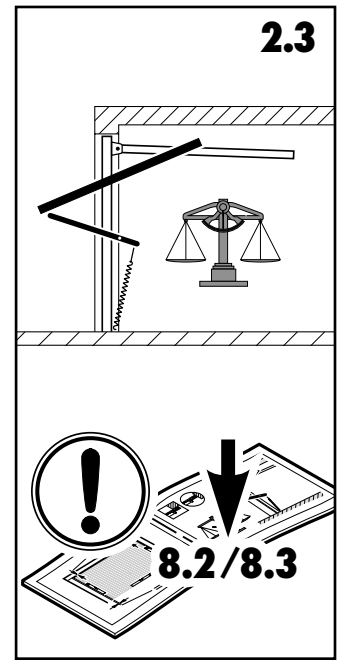
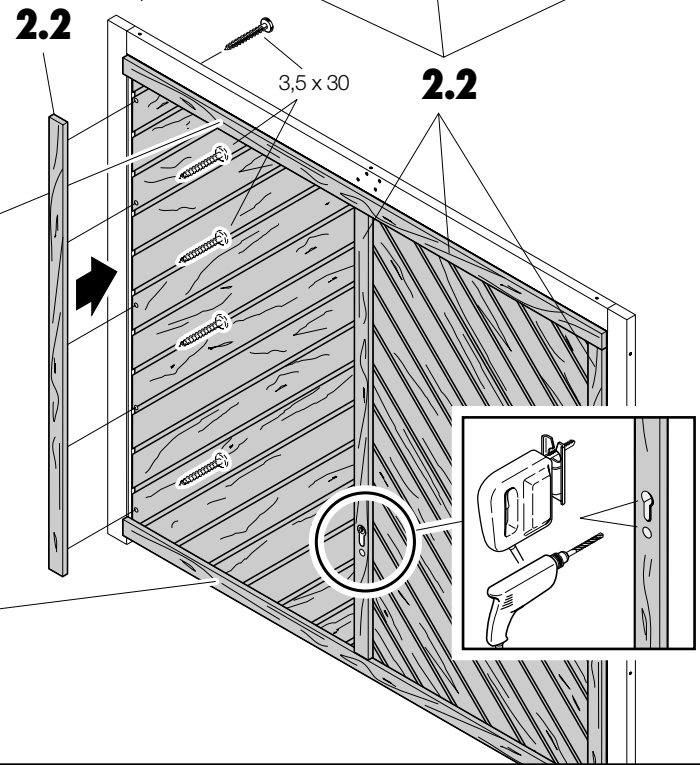
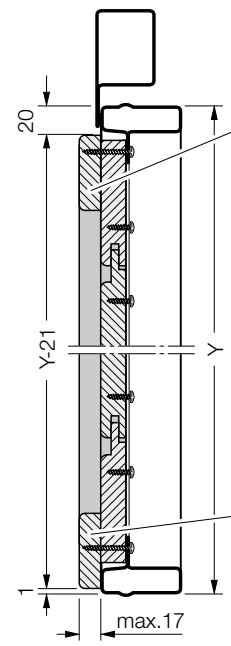
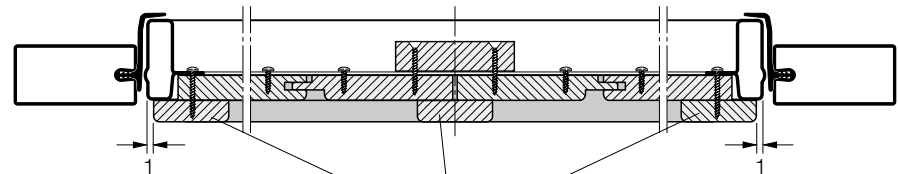
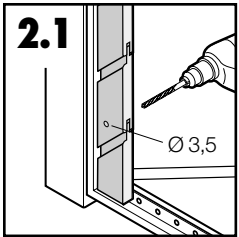

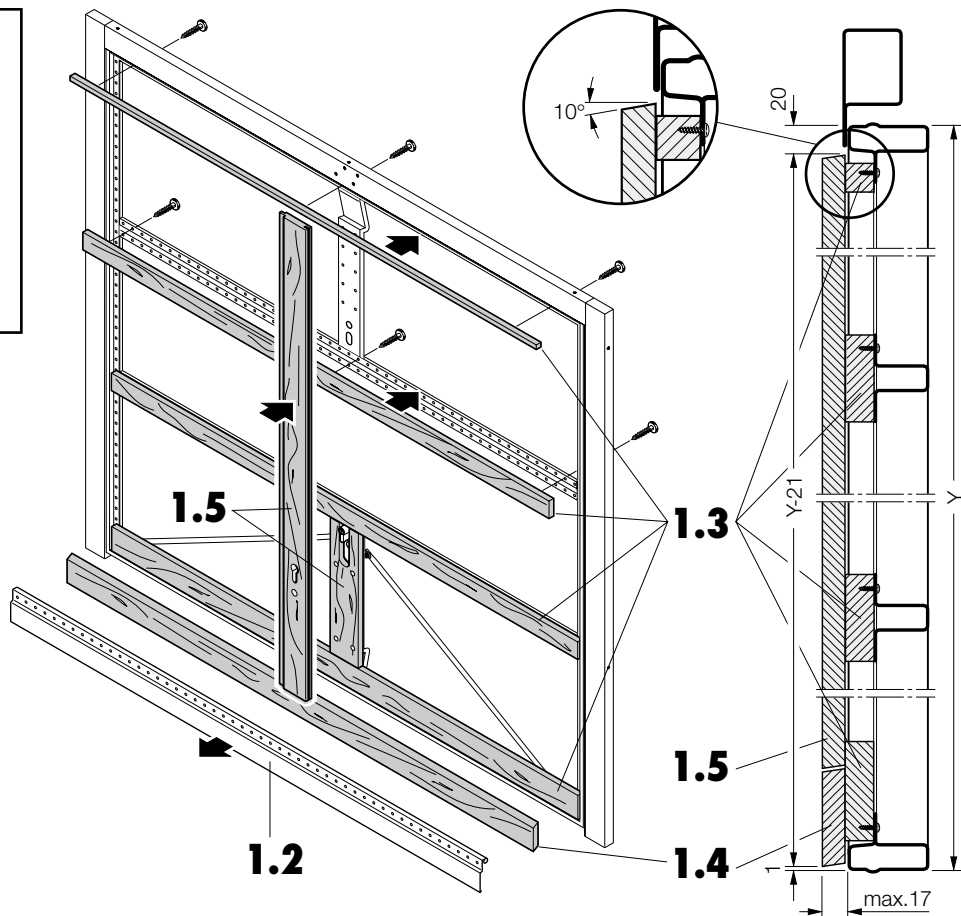
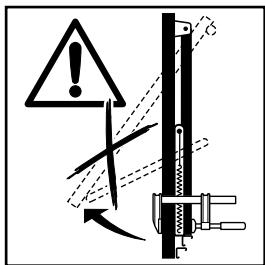
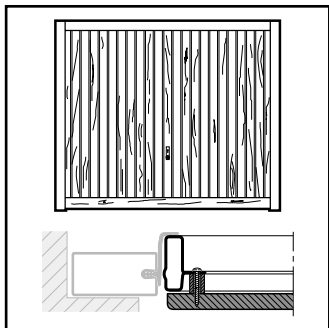

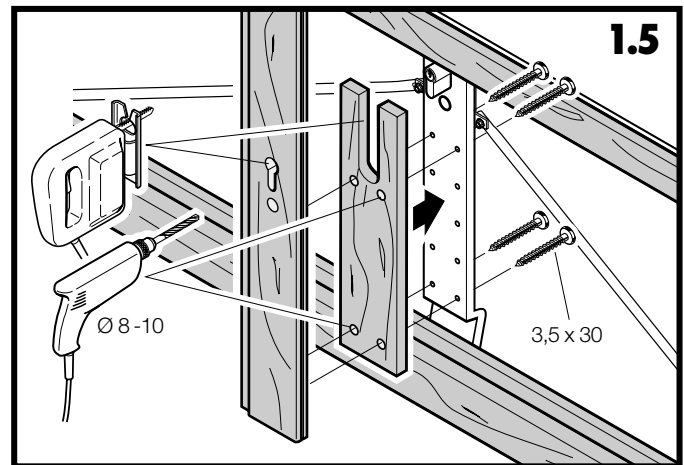
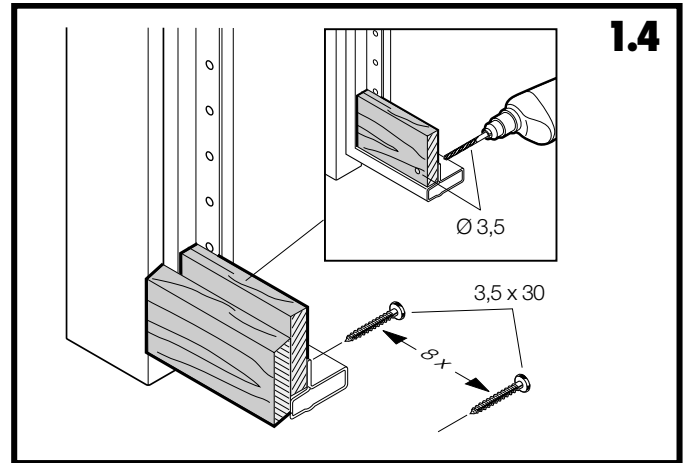
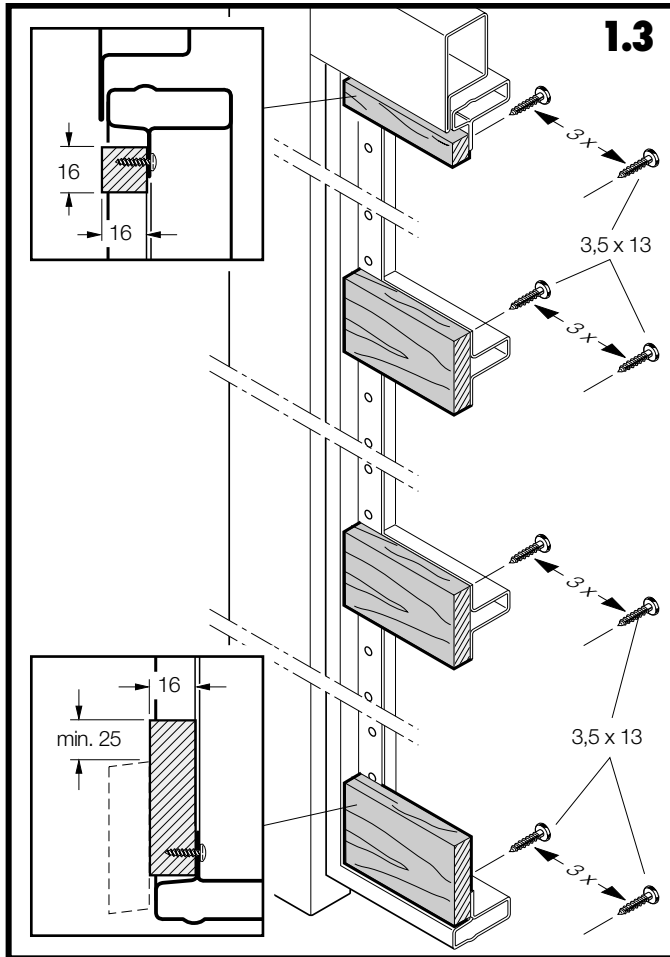

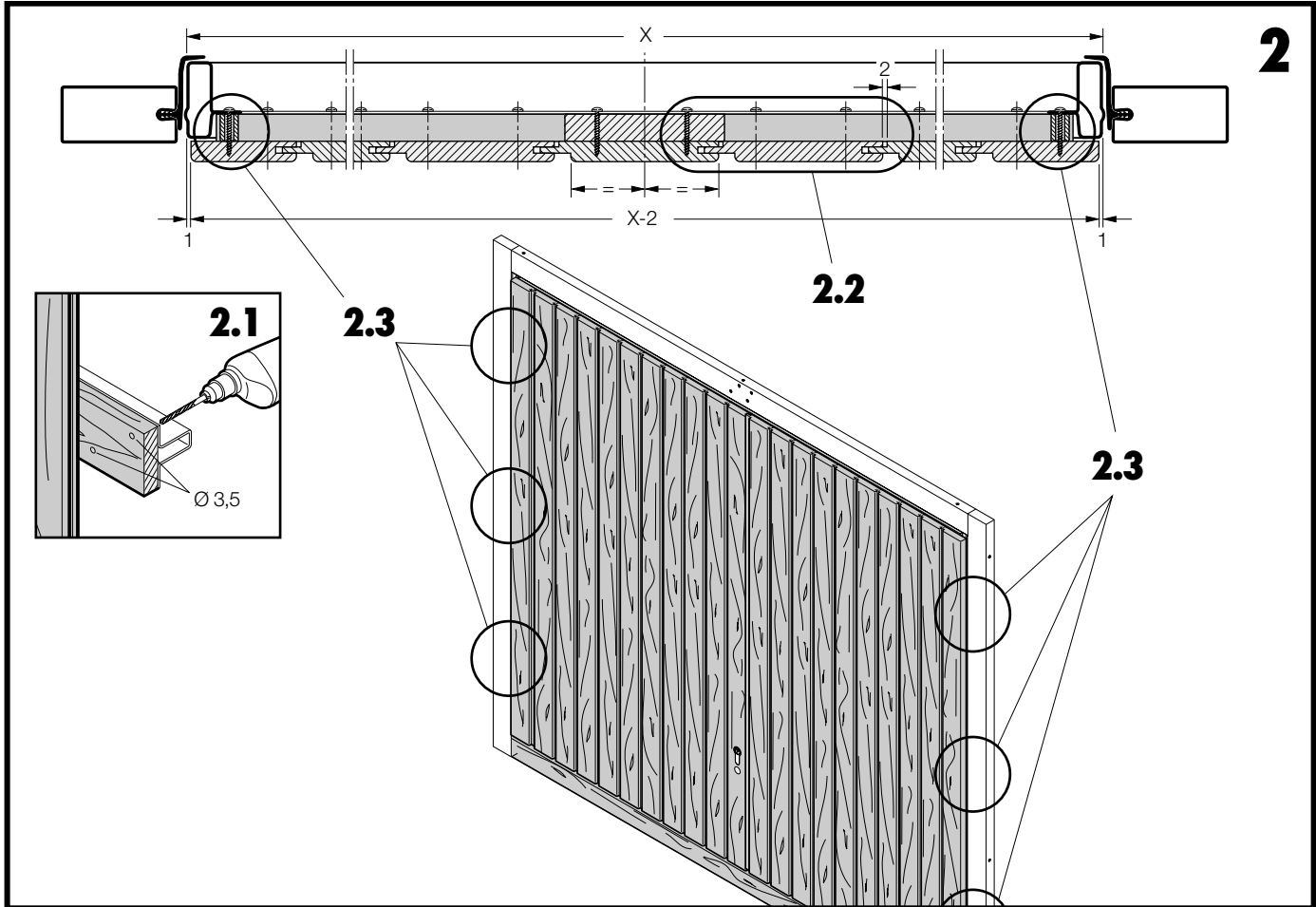

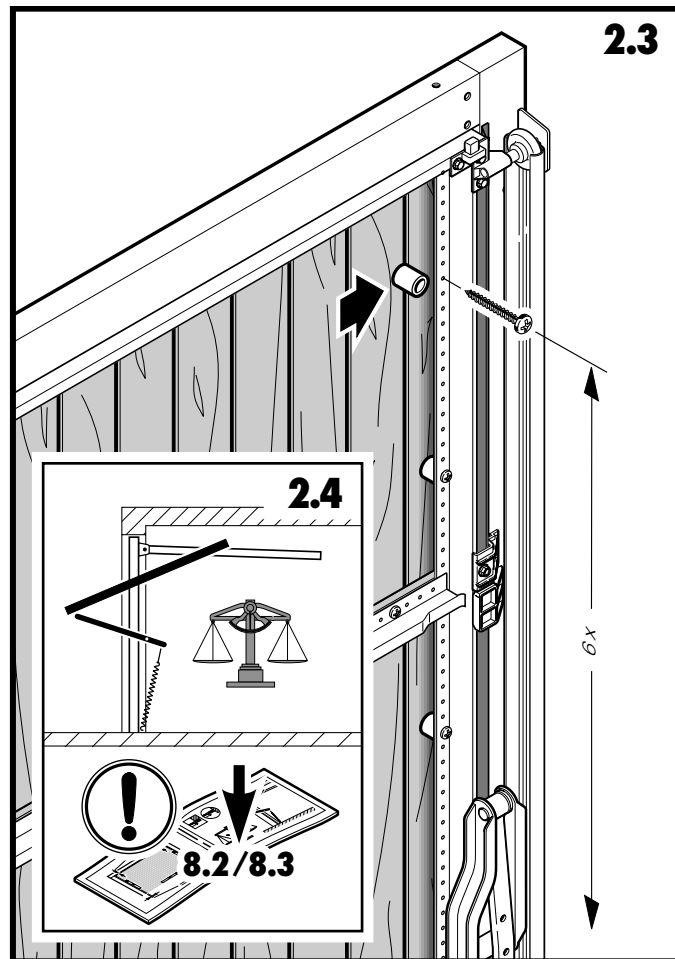
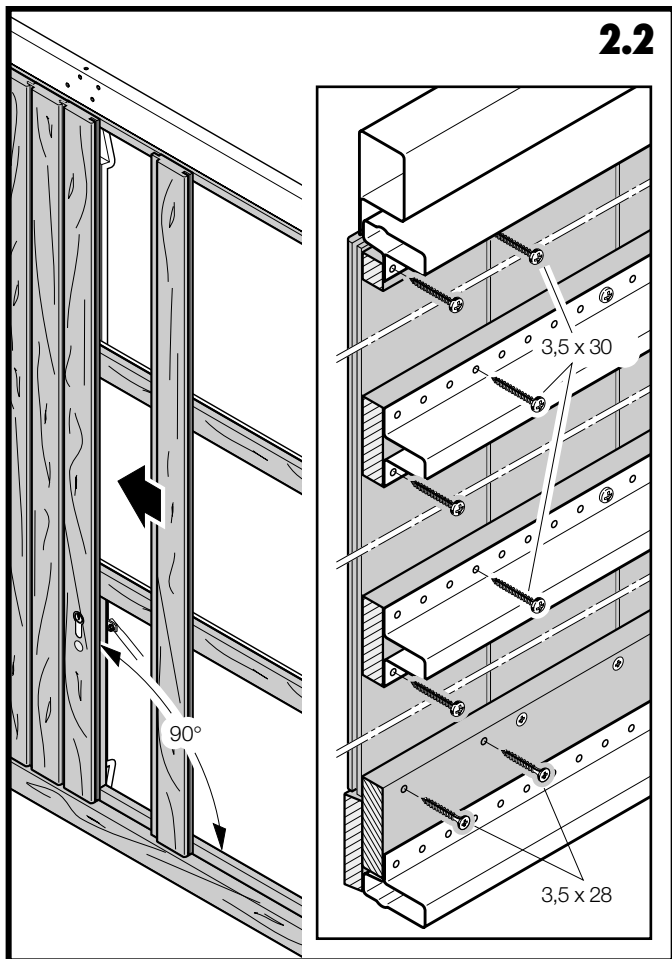

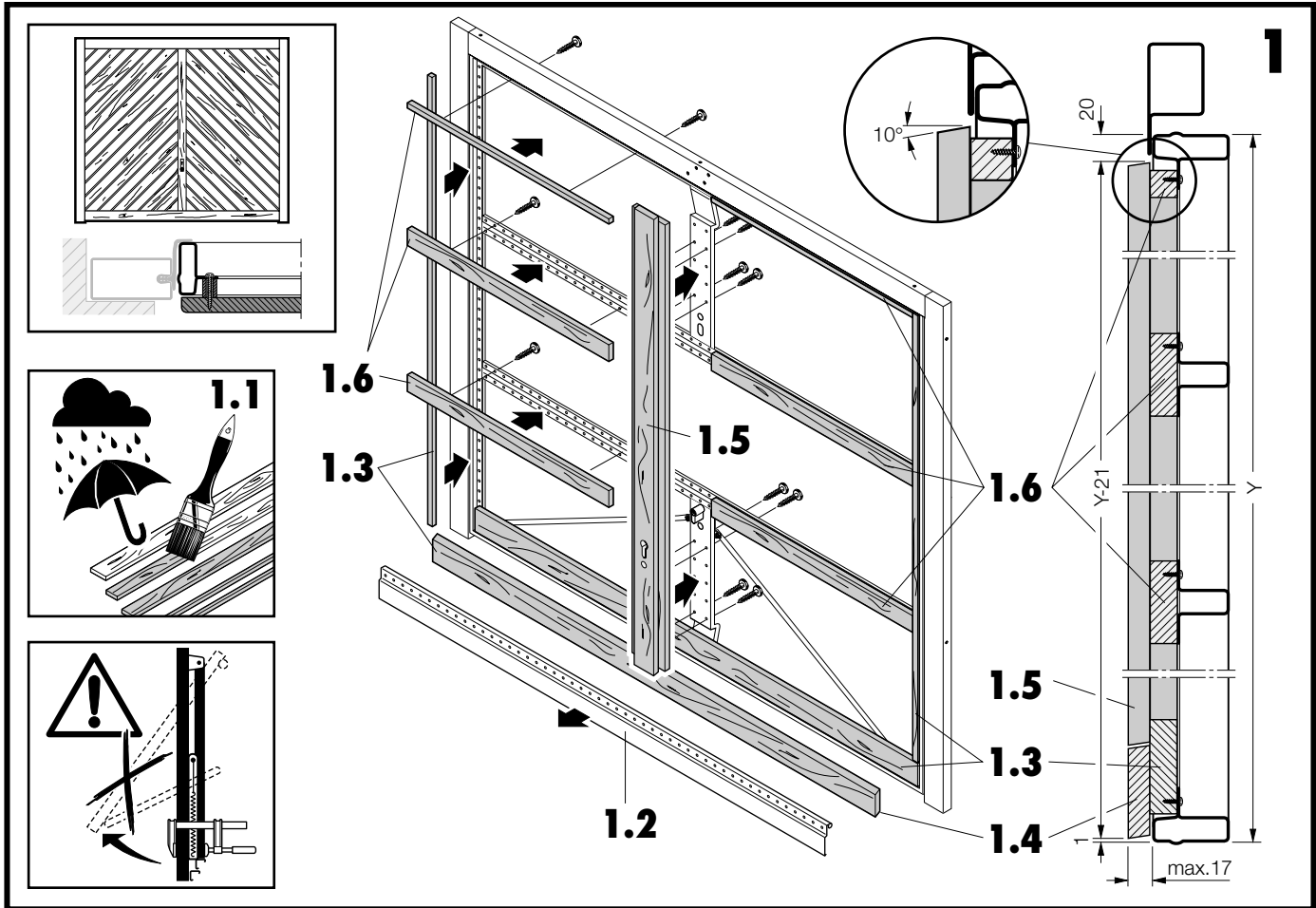

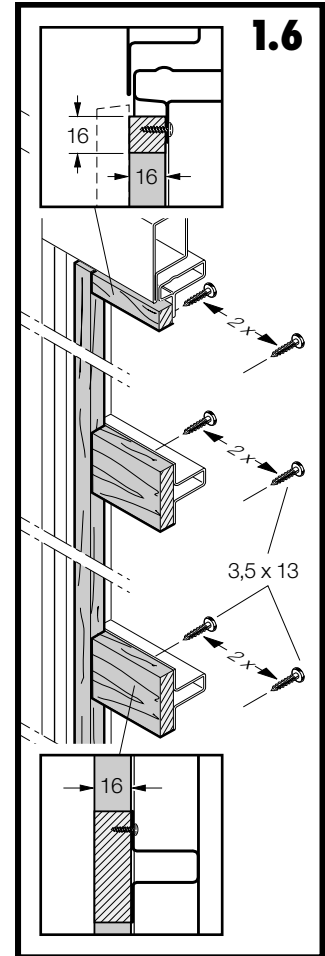
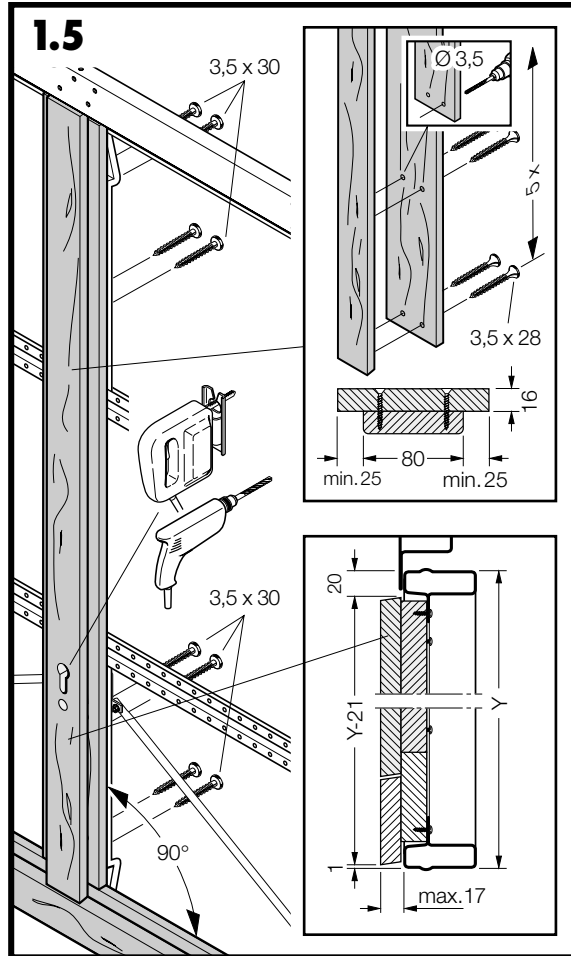
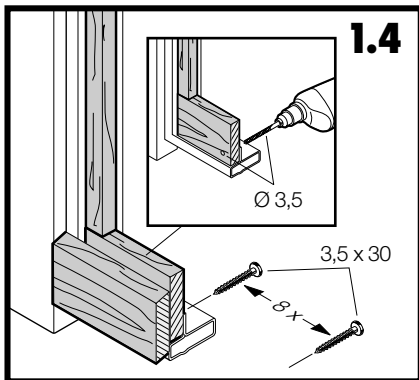
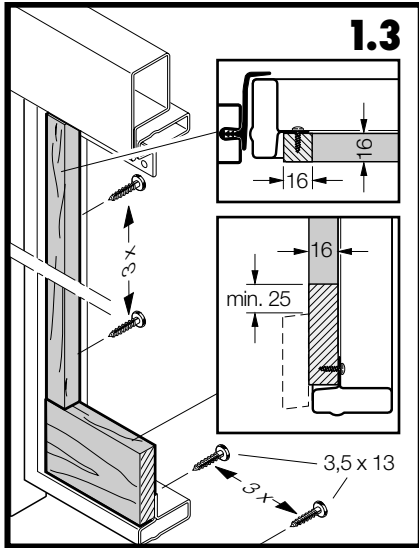

2

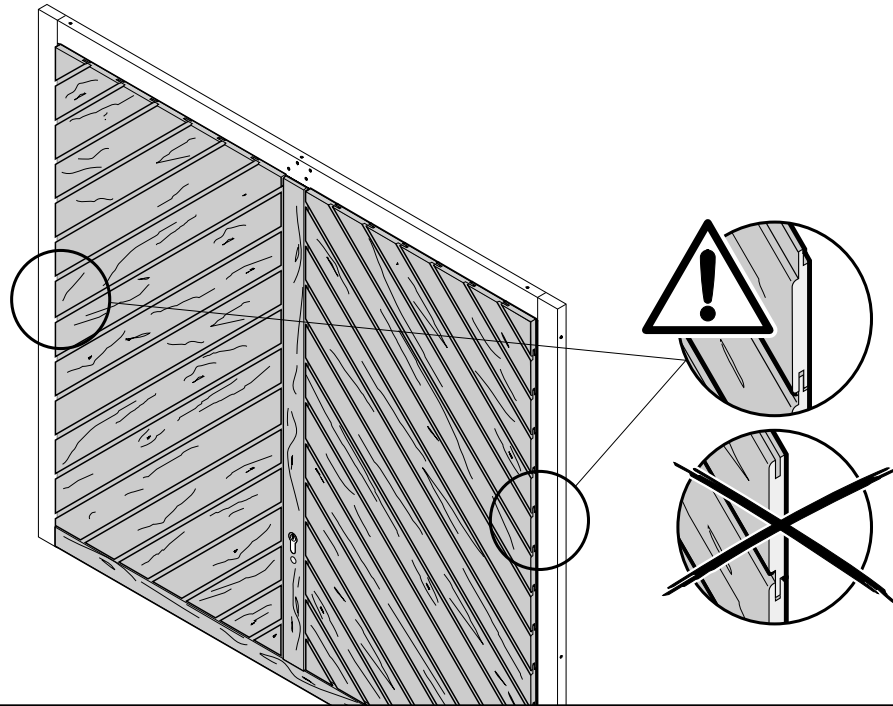
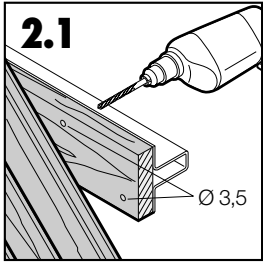
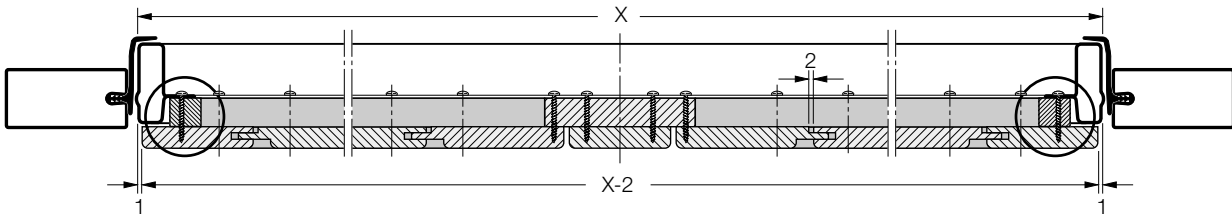

2.2

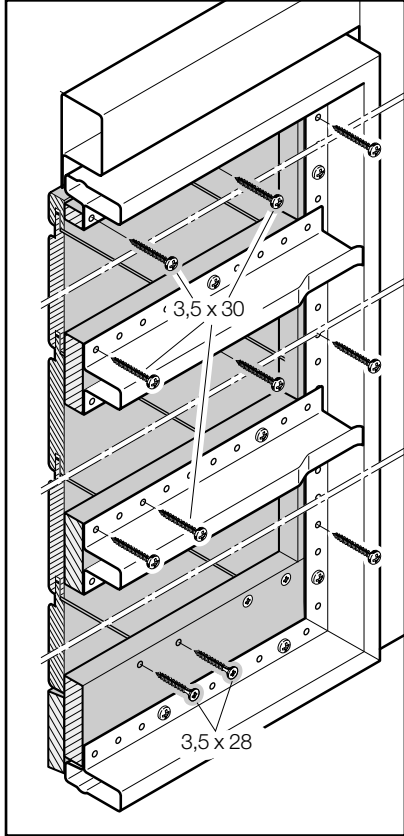
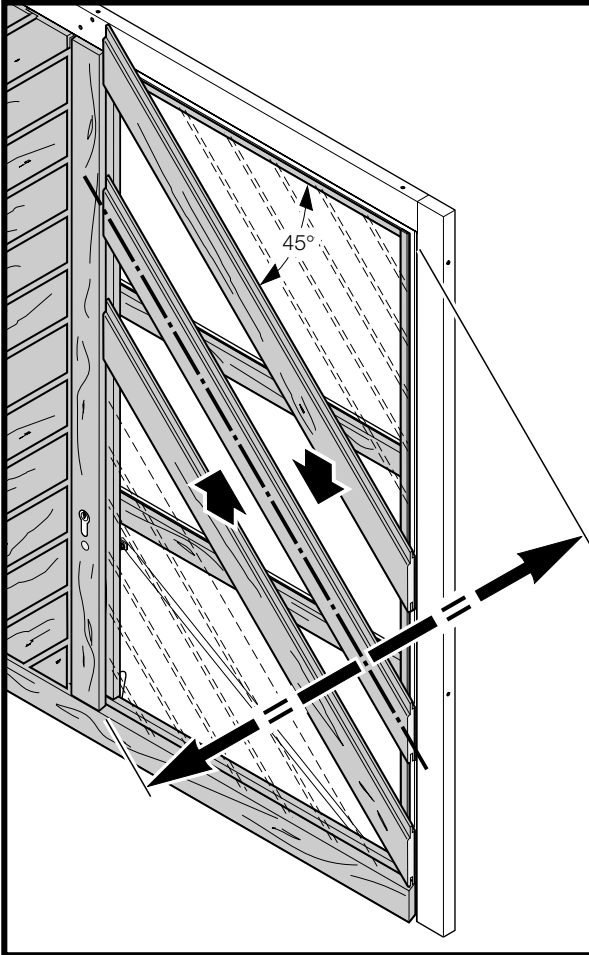

2.3

